

RETURN AIR GRILLE ACCESSORIES

B-A B-Type T-Bar Ceiling Frame

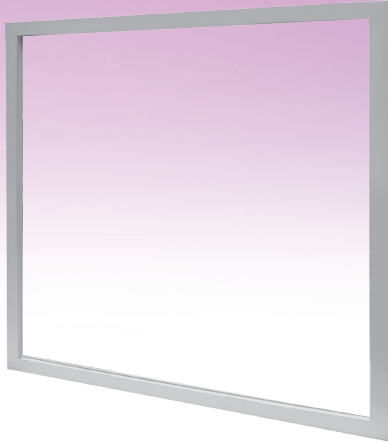

Materials

Extruded aluminium A6063.

Surface finish

Baked white powder coated or natural anodized

Features

- They are constructed of extruded aluminium and intended to be used as removable frame for the mounting of various types of diffusers.
- They are normally used in non T-bar ceiling suspension systems.
- Not applicable for wall mounted grilles.
- When mount at ceiling, the grille or diffuser will rest on the B type T-bar ceiling frame.

B-A Physical Dimension *Unit : mm*

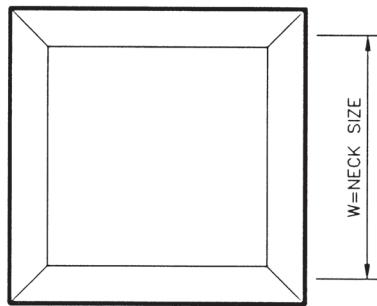

Top View

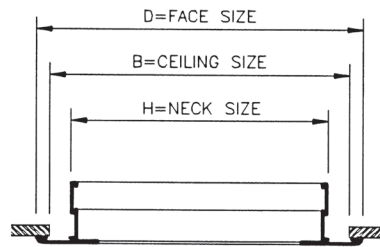

Side View

Model	W x H	B Ceiling Size	D Face Size
B-A	To suit grilles or diffusers	W+20 H+20	W+30 H+30

B-A Order Code

Model	Material	Neck Size
B	A	N 563 x 563

Example : B-A, N 563 x 563

RETURN AIR GRILLES ACCESSORIES

Return Air Grille + G1 Opposed Blade Damper

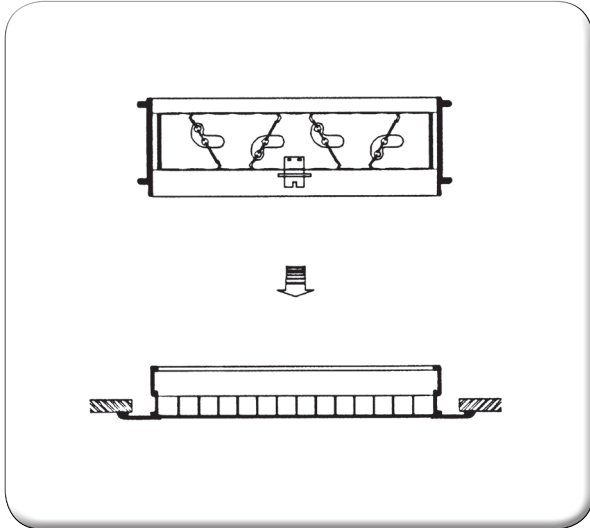

- The G1 OBD damper is designed for even distribution of air over the entire face of diffuser. It is screw operated & can be adjusted from below by screw driver. The damper can be set at fully open, half open & fully close.
- G1 damper are constructed of galvanized steel with baked black as standard finish.
- Height for G1 : 60mm.

Return Air Grille + D2 Adapter

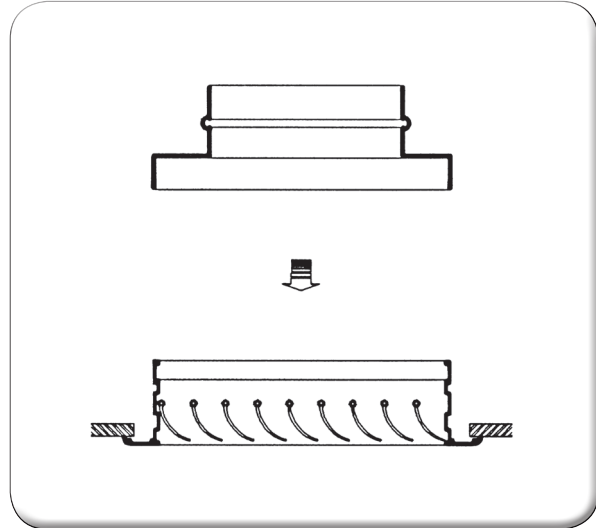

- With D2 adapter fitted to the return air grilles it makes installation of flexible duct become easier.
- The D2 adapter are constructed of 0.6mm galvanized steel with baked black as standard finish.

Return Air Grille + IS Insect Netting

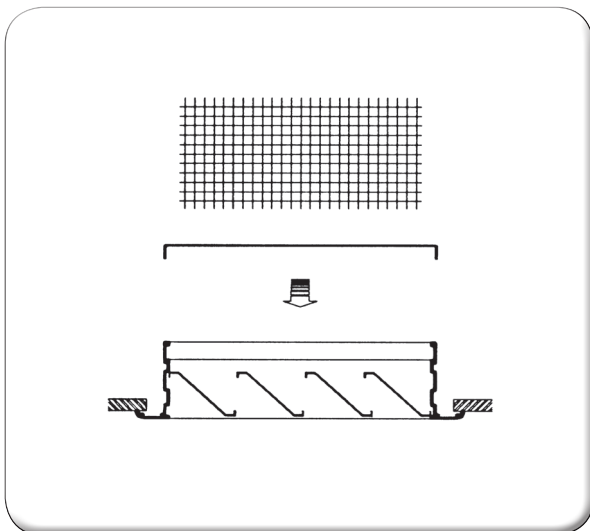

- The insect netting is constructed of wire mesh of gauge 24 (1"8 holes) installed at the grille.
- IS insect netting prevent scraps, debris and small animals from being sucked into the air duct.

RETURN AIR GRILLES ACCESSORIES

G1 Opposed Blade Damper

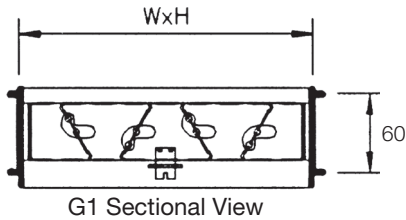
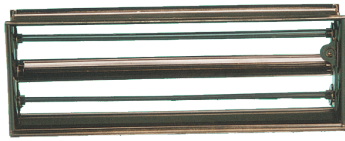

Materials

G1-T
Frame : 0.6mm galvanized steel.

Blade : 0.5mm galvanized steel.

Features

Screw or level arm, can be set at fully open, half open and fully close

Surface Finish

Black powder coated, oven baked as standard.

Size

Maximum dimension is 500mm x 500mm damper size bigger than this will come in sections.

D2 Collar

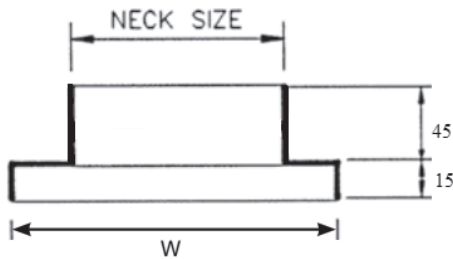
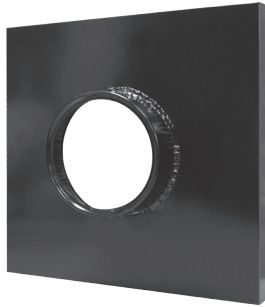

Materials

D2-T : 0.6mm SPGC galvanized steel.

Surface Finish

Black powder coated, oven baked as standard.

IS Insect Netting

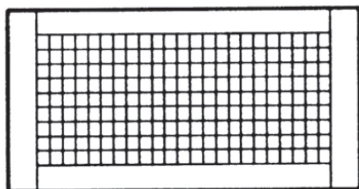
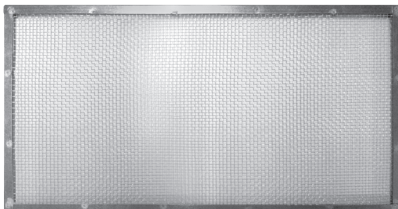

Materials

Frame 0.6mm galvanized steel.
Gauge 24 wire mesh.

Size

Wire mesh grid : 8 x 8 (Others available upon request)