

# SW-3T Fan Type Swirl Ceiling Diffuser



**ASLI SW-3T** is a type of diffuser with fixed radially arranged curved air control blades. The curve profile of the blades and opening allow the air to be delivered horizontally with cyclone characteristic, which provide better induction “vortex” air flow than normal straight profile swirl diffuser. Room temperature and air velocity will be reduced effectively to achieve excellent uniformity of temperature in a comfort air conditioned space. It can be used as supply or return air device.

## Materials

0.7 mm galvanized steel.

## Surface Finish

Baked white powder coated as standard.  
Others available upon request.

## Standard size *Unit : mm*

595 x 595 / 603 x 603

## Features

- Air delivered horizontally with cyclone characteristic.
- Low sound level at high air volume.
- The blades and the opening area are in curved profile.
- The diffuser face plate is removable (optional).

## Accessories

- C1 Radial fan blade damper
- C2 Crown damper
- D2 Adapter
- G1 Opposed blade damper
- PB-S Plenum box side entry
- PB-T Plenum box top entry

## SW-3T Physical Dimension *Unit : mm*

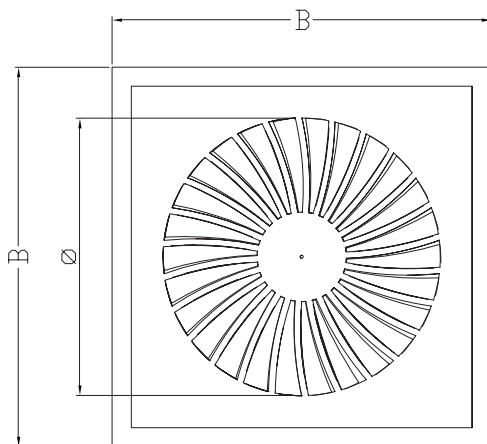

Top View



Side View

Model	B	ø	H
SW-3T	595 / 603	430	50

# SW-3T Fan Type Ceiling Diffuser

## SW-3T Construction Illustrations

**SW-3T + D2 + C2**

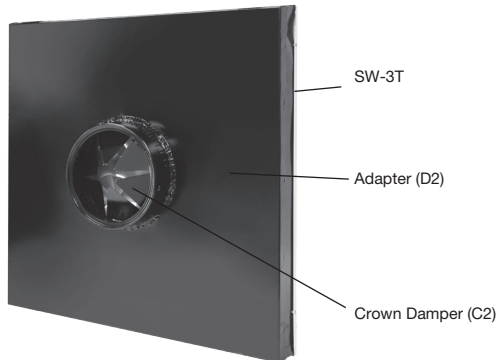

**SW-3T + D2 + G1**

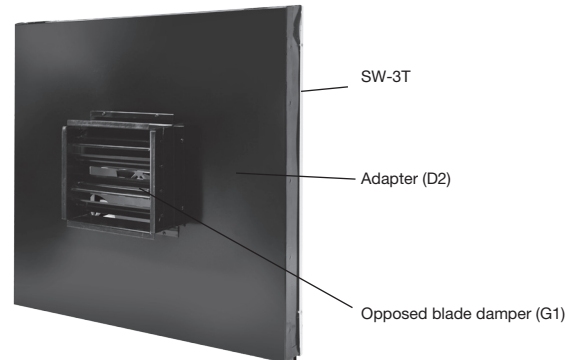

## SW-3T Air Flow Performance Data

Inlet Diameter (mm)	Collar Neck Vel. (m/s)	1.5	2.0	2.5	3.0	3.5	4.0	4.5	5.0	5.5	6.0
	Vel. Press (mmAq)	1.5	2.5	4.0	5.5	7.7	10.0	12.7	15.4	18.7	22.4
ø 150	CMH	97	129	161	194	223	254	286	318	350	382
	Tot. Press (mmAq)	0.3	0.6	1.0	1.4	1.9	2.4	3.0	3.5	4.3	5.3
	NC	-	-	-	-	-	-	24	27	31	34
	Throw (m)	0.7 - 1.3	1.0 - 1.7	1.0 - 2.0	1.3 - 2.0	1.7 - 2.3	1.7 - 2.3	1.7 - 2.6	2.0 - 2.6	2.0 - 3.0	2.0 - 3.0
ø 200	CMH	172	230	287	344	396	452	509	565	622	679
	Tot. Press (mmAq)	0.4	0.8	1.3	1.9	2.6	3.3	4.0	5.3	6.1	7.2
	NC	-	-	-	22	28	32	36	39	41	42
	Throw (m)	0.7 - 1.3	1.0 - 1.7	1.0 - 2.3	1.3 - 2.3	1.7 - 2.6	1.7 - 3.0	2.0 - 3.0	2.3 - 3.3	2.3 - 3.3	2.3 - 3.7
ø 250	CMH	269	359	449	538	619	707	795	884	972	1060
	Tot. Press (mmAq)	0.7	1.2	1.9	3.1	4.3	5.4	6.7	8.3	10.0	11.9
	NC	-	-	22	29	35	37	41	43	45	47
	Throw (m)	1.0 - 2.0	1.3 - 2.6	1.7 - 3.0	2.0 - 3.3	2.3 - 3.7	2.6 - 4.1	3.0 - 4.4	3.0 - 4.4	3.3 - 4.7	3.3 - 4.7
ø 300	CMH	388	517	646	775	891	1018	1145	1272	1400	1527
	Tot. Press (mmAq)	1.5	2.6	3.8	5.6	7.5	9.9	12.5	15.5	18.7	23.6
	NC	-	25	31	39	42	45	48	50	52	55
	Throw (m)	1.3 - 2.6	1.7 - 3.3	2.0 - 3.7	2.6 - 4.4	3.0 - 4.7	3.3 - 5.1	3.7 - 5.1	4.1 - 4.7	4.1 - 5.7	4.3 - 6.1

- Throw is based on terminal velocities of 0.5m/s and 0.25m/s respectively.
- Throw is based on isothermal condition.
- NC value is based on a room absorption of 10 dB, re 10<sup>-12</sup> watts.
- Dash (-) in space indicates NC value less than 20.

## SW-3T Order Code

Model	Accessories	Face Size	Neck Size
SW-3T	C1	B 603 x 603	N 200

Example : SW-3T + C1 - B 603 x 603, N 200